



# Explosion Venting EGV HYP

## FOR HYGIENIC APPLICATIONS WITH LOW OVERPRESSURE OR VACUUM

### Applications

EGV HYP was specially developed for demanding hygienic applications in the food and pharmaceutical industries. It is frequently used in critical plants to protect spray dryers, filters or fluid bed dryers. This has been confirmed, among others, by the **EHEDG Cleanability Test**.

**Special feature:** The patented, full surface, tapered sealing system fits flush with the interior of the explosion vent and **prevents cross contamination**. The explosion vent can also be pre-bent to round vessel shapes.

### Mechanism

When pressure rises, the explosion vent opens at the defined breaking point and releases pressure out of the vessel into the surrounding area.

### Your advantages

- Hygienic design ensures consistently **high product quality**.
- **Protects from cross contamination** upon change of product.
- Allows **CIP cleaning**.
- **Longer lifetime** of explosion vent under extreme temperatures and strain from pressure alternations – thanks to integrated bionic structure.
- **Reduced noise emissions** (e.g. through knockers) on discharge channels.

Made in Germany



#### Technical data\*

Standard burst pressure P <sub>stat</sub>	0.1 bar
Max. permitted operating pressure	50% of P <sub>stat</sub>
Temperature	-40 to +180 °C (-40 to +356 °F)
Material	Stainless steel
Gasket material	Full-scale silicon seal (FDA-licensed, hygienic performance)
Tolerance	±20% at standard burst pressure
Process	Non-pulsating
Recommended torque for M10 screws	15–20 Nm

\*Our specialists will be pleased to assist you in finding a solution that matches your specific operating conditions.



ATEX EC type examination certificate no. FSA 04 ATEX 1538 X

SIL equivalent SIL 4

You can find detailed information and contact details for enquiries relating to EGV HYP explosion vents at [www.rembe.de](http://www.rembe.de). Give us a call on: T +49 2961 7405-0 or contact us via email: [info@rembe.de](mailto:info@rembe.de).





Safety is for life.™

## PRODUCT INFORMATION

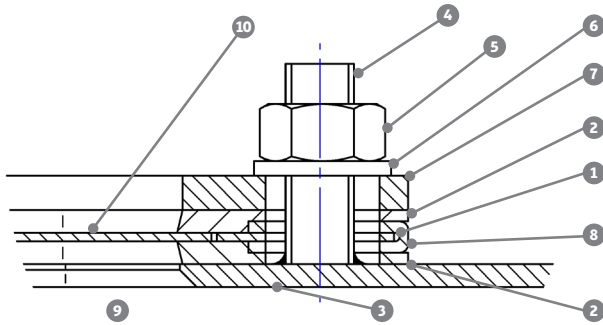

- 1 Explosion vent (burst element, integrated gasket and integrated frame)
- 2 Integrated silicon gasket
- 3 Vessel wall (opening dimensions +0/-2 mm)
- 4 Threaded bolt
- 5 Nut
- 6 Washer
- 7 Counter frame
- 8 Integrated frame
- 9 Opening
- 10 Burst element

Installation with welded threaded bolts.

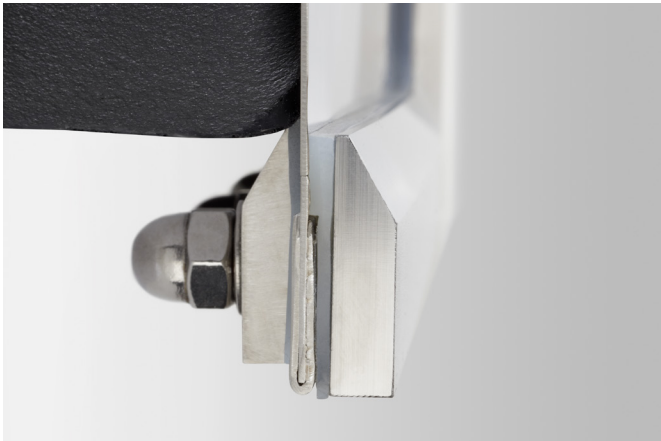

The specially developed sealing system prevents product deposits.



The outside is insulated to prevent condensation-related product built-up.

### Standard dimensions

Max. size of wall opening – nominal vent dimensions [mm]	Effective venting area [cm <sup>2</sup> ]
305 × 610	1860
490 × 590	2890
586 × 920	5400
610 × 1118	6800
920 × 920	8500
915 × 1118	10230
1000 × 1000	10000
1020 × 1020	10400

Other dimensions available on request.

Consulting. Engineering. Products. Service.

**REMBE**® GmbH Safety+Control

Gallbergweg 21 | 59929 Brilon, Germany | T +49 2961 7405-0 | F +49 2961 50714  
info@rembe.de | www.rembe.de